



If you wish to add anyone to the e-News list please do so by clicking the following link: [SUBSCRIBE](#)

Quick Information Lookup

- WCWWA Annual Conference
- Communication Performance Testing for SCADA Systems (White Paper)
- ACE3600 RTU: Advanced Performance, Advanced Communication

WCWWA - 60th Annual Conference

PROTECTING OUR WATER 60 YEARS OF SERVICE

CTH Systems Inc is pleased to once again be apart of the annual WCWWA tradeshow and conference.

September 23 - 26, 2008

Delta Regina Hotel - Regina, Saskatchewan

COME CELEBRATE WITH US IN THE LAND OF LIVING SKIES

Conference Schedule

Tuesday Sept. 23, 2008

- Workshops
- Tradeshow (6pm - 10pm)

Wednesday Sept. 23, 2008

- Tradeshow
- Technical Program

Dan Brabec, Motorola US, will be presenting a paper by Dan Ehrenreich, Motorola Isreal, on ***Planning for Optimal Control over Water System Operation*** on Wednesday September 23 at 2:00pm.

For more information on the WCWWA Conference, please visit their website.

<http://www.wcwwa.ca/2008/2008wcwwa.htm>

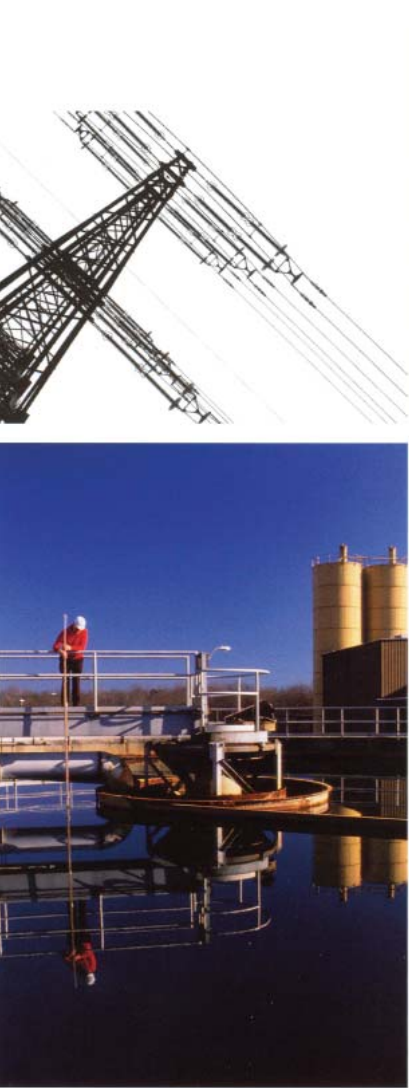



Communication Performance Testing for SCADA Systems (White Paper)

Dan Ehrenreich, Motorola Inc.

Overview

Supervisory Control And Data Acquisition (SCADA) solutions must provide reliable and timely communications, and have tested interface to a wide range of instrumentation and field sensors and SCADA control centers. This means that messages sent from the control center to the Remote Terminal Unit (RTU), directly (point to point) or via one or more repeaters or from RTUs to the control center, must be delivered on time and reliably. Furthermore each message is to be confirmed for correct acceptance, or information on rejection or failure must be returned to the sending entity. When the utilized media is fiber optic, usually the communication is close to ideal and unless there is a media malfunction the system operates seamlessly. However when any wireless media is used, the implementation requires more attention in order to achieve communication reliability. Today it is known for both RTUs and Programmable Logic Controllers (PLCs) that they may operate over variety of wireless or physical media; however, they don't deliver identical performance when it comes to data reliability. As customers usually acquire just one vendor's RTU and communication media, it becomes difficult for them to perform any comparison process.

Wireless Communication Media

Among the typical wireless media utilized for SCADA systems one can find licensed and non-licensed channels, dedicated/private or public networks, different communication methods, etc:

- a. **Analog Conventional VHF and UHF Radio:** These are narrow band (12.5 or 25 kHz bandwidth) voice radios and are operating over licensed channels. Typically they provide transparent data communication at the rate of 1200 - 9600 b/s, utilizing DFM, FSK or DPSK method.
- b. **Analog Trunking VHF, UHF, 800 MHz radio:** These are narrow (12.5 kHz bandwidth) band voice type radios, connected with a central channel controller and are operating over licensed channels. Typically they provide transparent data communication rate at the rate of 1200 b/s, utilizing DPSK method. Here it is important that one pays attention to the selected data protocol.
- c. **Analog VHF, UHF, 900 MHz Multiple Address system (MAS) radio network:** These are narrow band (12.5 kHz bandwidth) radios operating over dual licensed channels and have analog or RS-232 interface. Typically they provide transparent data communication at the rate of up to 9600 b/s and are utilizing DFM method.
- d. **Digital VHF, UHF, 800 MHz Integrated Voice and Data (IV&D) network:** These are also narrow band (12.5 kHz bandwidth) radios operating over licensed channels and integrated with the RTU using IP connectivity via RS-232 interface. These networks provide data communication up to 9600 bps. Here the data delivery to each site (addressing) is handled by the network.
- e. **Digital wide-band 900 MHz and 2400 MHz Spread Spectrum network:** These are wideband radios, typically operating over non-licensed channels and are integrated with the RTU using RS-232 serial port connection or IP connectivity via Ethernet or RS-232 interface. They provide data communication rates up to 512 k b/s.
- f. **Digital wide band 900/240/3700/5700 MHz Spread Spectrum network:** These are wideband radios operating over non-licensed channels and are integrated with the RTU using RS-232 serial port connection or IP connectivity via Ethernet. They can serve as an alternative to physical media backbone and provide data communication up to 1 Mb/s.

- g. **Digital wide band General Packet Radio Service (GPRS):** These cellular commercial networks use 900/1800 MHz or 950/1900 MHz radio modems operating in parallel with the Global System for Mobile (GSM) communication network: This wideband radio solution is usually external to the RTU and using IP connectivity via RS-232. They provide 56 -114 Kb/s data rate.
- h. **Digital and Analog Microwave network:** These point to point radios (requiring line of sight) are operating over wideband GHz range licensed channels and are integrated with the RTU using RS-232 serial port. They can provide data communication rates up to 1 Mb/s.
- i. **Digital Satellite network:** These are wideband radios operating over wideband GHz range licensed channels and integrated with the RTU using RS-232 serial port. They can provide data communication rates up to 100 Mb/s.

Communication Network Selection

When analyzing the SCADA-Data Communications process and its adaptability for a specific-identified SCADA solution, the following considerations may apply:

- a. **Transparent vs. Data Handling.** Does the network offer absolutely transparent communication between RTUs connected via the radio, or the radio includes some type of data handling, such as error detection and correction, data routing, data encryption, etc.?
- b. **Private vs. Shared.** Is the network defined as “private,” where the loading is controlled by the network owner/operator, or is the network sharing consumer channel resources (cellular or spread Spectrum) where no one can neither control nor predict the expected loading at any moment?
- c. **Common vs. Stand-alone Infrastructure.** Does the network operation require installed infrastructure (data entry nodes, repeaters, computers, etc.) or it is completely stand-alone operating, so that the data routing is controlled by the utilized SCADA system/RTU protocol?
- d. **Industrial vs. Commercial Standard.** Does the available radio unit meet industrial quality level/standards or is only consumer/commercial level equipment available? Are the considered radios capable of operating in outdoor temperature and humid conditions and were these tested to meet the most common industrial standards?
- e. **Formal Type Approval/Certification.** Were the selected radios certified to operate in the country where they are to be installed? In case the radio is installed within the RTU, was the complete assembly (with a dedicated model number) homologated for the country of the end user?

Factors Influencing Data Reliability

Upon analyzing the quality of the communication channel one can point out several factors which may affect the operating reliability of the system. Among the most visible factors are:

- a. **Received Signal Level:** This parameter influences the data reliability, since during low signal condition errors might not be corrected and cause system downtime. In other cases the effective data rate might slow down, as complete messages need to be retransmitted.
- b. **Modem Modulation:** Selecting the utilized method RF signal modulation can be as important as selecting good quality hardware. For example, the DPSK modulation results in slower data rate but deliver more reliable data communication than FSK or DFM.
- c. **Radio Hardware Quality:** In case of extreme operating temperature, outside of the normal operating range of the radio unit, the data recovery process might not be as accurate as required and therefore cause appearance of data errors.
- d. **Data Communication Protocol:** Some SCADA protocols are more robust than others and in case of extreme conditions which might cause losing data packets (weather related lightning) or interference, the less robust protocols used over wireless media are less reliable.

System Testing Method

Figure 1 illustrates a simplified test diagram involving a minimum of three remote units but preferable up to five units connected in the network. In this test system each remote unit has 4 AI, 4 AO, 4 DI and 4 DO. Upon receipt of a message at the remote site (including 4 status points and 4 analog values), these values will be retransmitted as immediately as possible to the sending site. It is recommended that the test will be conducted during seven days and performed every 30 seconds. Therefore the total number of transactions will be $3 \times 7d \times 24h \times 120 = 60480$. However, as each message is being resent by the RTU to the FIU, there will be over 120,000 transactions. Performing this test may provide enough information about the data communication reliability achieved with the selected RTU type, selected media and data protocol. Upon completion of this test the results may be uploaded to an Excel file as shown in Table 1 and statistical information can be produced. As seen in the example below, the first transaction was successful and returned within 20 seconds. The 2nd transaction did not returned at all, while the 3rd transaction returned after significant delay. Refer to the following notes:

- The system can send the same messages or send incrementally progressing values
- Comparison can be performed with combination of different RTUs and communication media
- Use of the DNP 3.0 protocol is important as it support communication of time-stamp data.

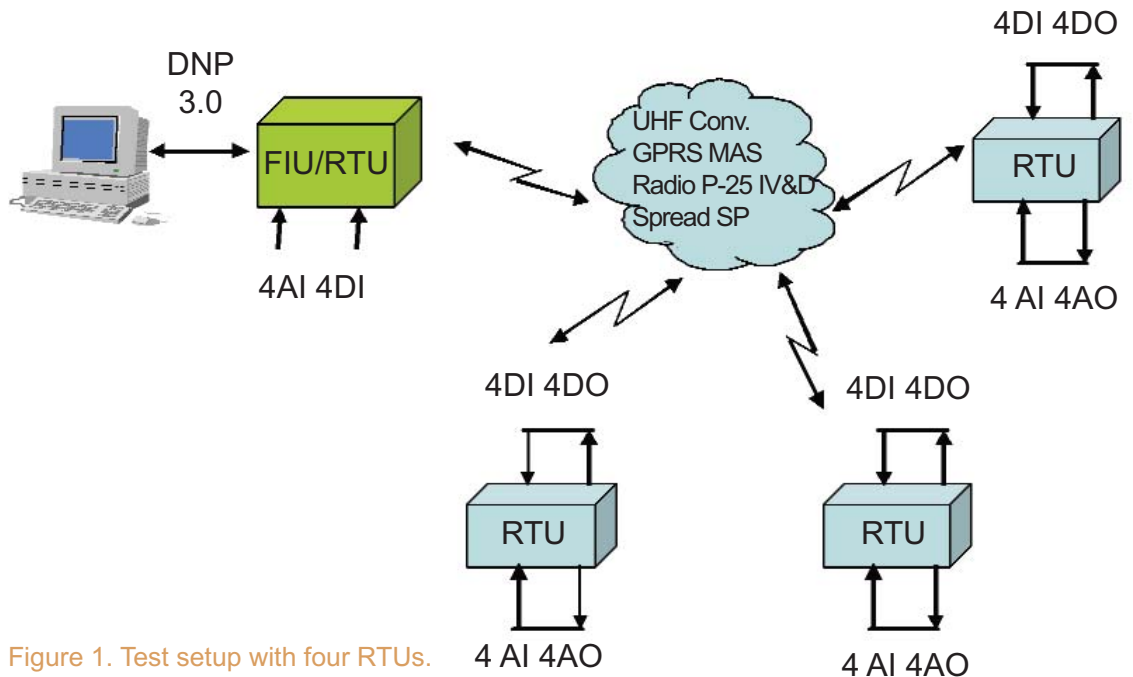

Figure 1. Test setup with four RTUs.

Table 1. Test result for 3 consecutive transmissions

Value 4 Bit Status	Value Analog 1	Value Analog 2	Value Analog 3	Value Analog 4	Time Tx Source	Time Rx Remote	Time Tx Remote	Time Rx PC	Success 1 or 0	Round Trip Time (sec.)
15	12,059	12.056	12.059	12.059	12:03:00	12:03:05	12:03:15	12:03:20	1	00:00:20
15	12,059	12.056	12.059	12.059	12:03:00				0	
15	12,059	12.056	12.059	12.059	12:03:00	12:03:05	12:03:15	12:03:20	0	00:00:20

@@@@@@@@@@

ACE3600 RTU: Advanced Performance, Enhanced Communications

Motorola's new ACE3600 RTU (Remote Terminal Unit) combines modern and innovative design, control and data communication features that enhance the performance and operating reliability of SCADA (Supervisory Control and Data Acquisition) systems for a wide range of applications. SCADA solutions can help to simplify maintenance procedures and reduce operating costs – the ACE3600 enables remote sites to be monitored proactively and corrective responses to be made instantly, reducing the interruption of services to customers.

Ideally suited to water and electric utilities, public security and oil and gas applications, the ACE3600's powerful processing capabilities provide advanced calculations and data analysis for critical, real-time monitoring and control functions. Its ability to emulate a range of third party communication protocols enables data to be gathered and analysed from multiple sensors and intelligent electronic devices installed at remote sites.

The ACE3600's advanced communication capabilities allow it to operate simultaneously as a wireless or wireless-to-other media communication node. The SCADA system can operate through radio, cellular, microwave, fibre optic, dedicated or switched wirelines, RS-232/RS-485 serial links, Local Area Networks (LAN) or a versatile data network combining these media. Utilising a single radio channel, it can also operate as a Store and Forward data repeater to cover a wider geographical area and provide redundant data transfer links to multiple ACE3600 RTUs linked to the SCADA network.

A Wide Range of Applications

The ACE3600 RTU provides electric utilities with the ability to automate their power distribution grid through the computerised remote control of medium voltage switchgears and substations. By enabling over-the-air RTU operation diagnostics and programming, this solution increases the productivity of maintenance teams and can reduce the number and length of power interruptions to customers.

Oil and gas operations can enhance operational safety by using the ACE3600 to detect leakages, perform gas flow calculations, monitor pressure along pipelines and control valves located at remote sites. In an emergency, the ACE3600 also has the ability to trigger wide area warning via multiple sirens and use select combinations of tones to activate pre-recorded warning messages.

The ACE3600 can be configured to monitor water flow along pipe lines, cut down on unnecessary consumption and improve the regulation of water pressure. Water utilities are able to realise significant cost savings by reducing Unaccounted for Water (UFW) losses, improving the management of water and reducing energy supply through the smart activation of water pumps.

For emergency services, a quick and accurate response to incidents can minimise loss of lives. On receipt of an alert at a fire station, the RTU can be programmed to turn on lights, connect the voice dispatch message to the building's public address system, open the fire station doors and activate selected vehicles.

Versatile and Easy to Use

Motorola designed the MOSCAD (Motorola SCADA system) family of RTUs and the new ACE3600 to accommodate both vertical as well as horizontal system expansion, enabling customers to enhance and expand their SCADA systems cost-effectively. With the modern Windows™ based System Tool Suite (STS), engineers have a flexible and intuitive tool that allows them to maintain, design, configure, programme and upgrade ACE3600-based SCADA systems. The remote maintenance capabilities of the ACE3600 improve the speed and ease with which modifications can be implemented.